



2003 BEECHCRAFT PREMIER I





AIRCRAFT OVERVIEW

2003 BEECHCRAFT PREMIER I

HIGHLIGHTS

- Rockwell Collins Pro Line 21 Avionics Suite
- Seven (7) Passenger Accommodation
- Engines Enrolled on TAP Blue
- Exceptional Ownership Pedigree

AIRFRAME

Serial Number	RB-77
Base Location	Idaho, USA (KCOE)
Entry Into Service	2004
Total Hours*	5,054.2
Total Landings*	4,582

ENGINES

	Engine 1	Engine 2
Williams FJ44-2A		
Serial Number	105061	105064
Total Hours*	5,019.4	5,019.4
Total Cycles*	4,575	4,575

PROGRAMS

Engines	TAP Blue
Maintenance	CAMP

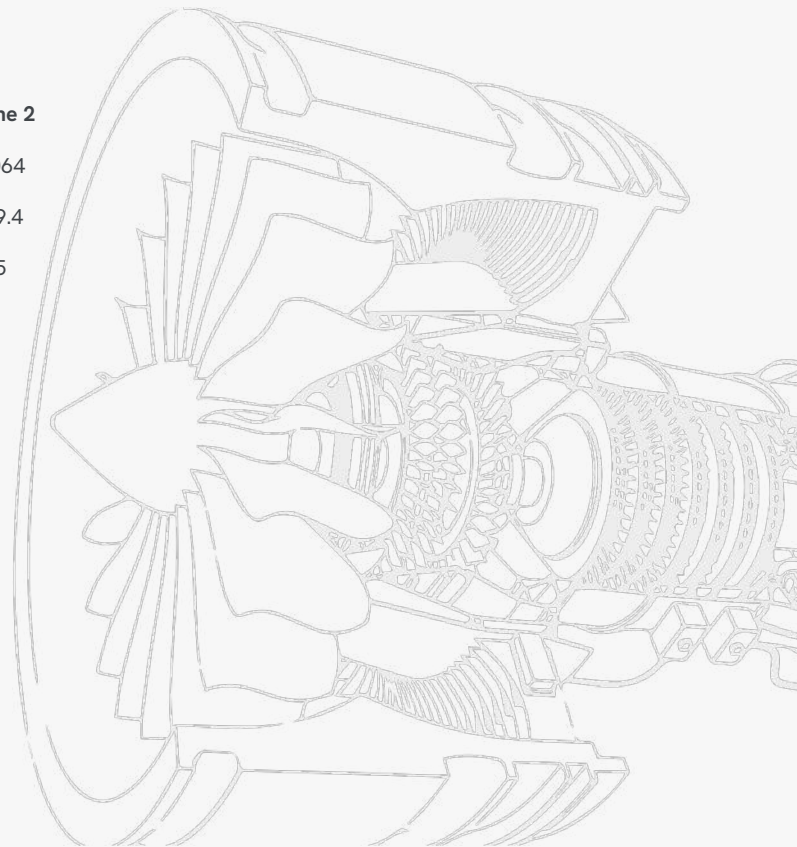

*All Hours & Cycles as of November 2023



PRO LINE 21 AVIONICS SUITE

- **EFIS:** Collins Pro Line 21; 3-Tube
- **AHRS:** Dual Collins AHC-3000
- **CVR:** L3 FA-2100; 120-Minutes
- **RMI:** Collins SDU-640
- **FMS:** Collins FMS-3000
- **EGPWS:** Honeywell MK V
- **AUTOPILOT:** Collins FGC-3000 IFCS
- **TAWS:** Class A
- **FDS:** Dual Collins FGC-3000 IFCS
- **TCAS:** TCAS II
- **RADAR:** Collins RTA-800
- **NAVS:** Dual Collins VIR-432
- **RAD ALT:** Collins ALT-4000
- **ADF:** Collins ADF-462
- **VHF:** Dual Collins VHF-422C
- **DME:** Dual Collins DME-442
- **XPNDR:** Dual Garmin GTX-3000; Mode S
- **GPS:** Dual Collins GPS-4000A





ADDITIONAL FEATURES

- ADS-B Compliant; Elliot Aviation
- DBU-5000 Upgrade
- Garmin FlightStream 110
- Dual Starter-Generators
- Environmental Heating System
- Automatic Pressurization Controller
- 77 Cu Ft Oxygen System
- Fire Extinguisher
- Dual Engine-Driven Hydraulic Pumps
- Hydraulic Extension & Retraction Landing Gear & Brakes
- Remote Low Engine Oil Sensor System
- Aft Baggage Heat
- RVSM/MNPS Compliant
- Cabin Briefer System
- Dual Electronic Flight Bag System (EFB)
- LoPresti Boom Beam Landing Lights
- Recognition Lights





INTERIOR

Configuration / PAX:

Six (6) Passenger Executive Cabin Seating +
One (1) Co-Pilot Seat = Seven (7) Passenger Seats Total

Seating:

Forward Four (4)-Place Club w/ Fold-Out Tables

Aft Dual (2) Forward Facing Seats

Refreshment Center:

Forward RH Refreshment Center & Storage

Lavatory:

Aft Lavatory

Notable Features:

Dual 110-Volt AC Outlets

First Aid Kit

Condition:

Refurbished July 2013



*Displayed color swatches
are an approximation*





LAYOUT

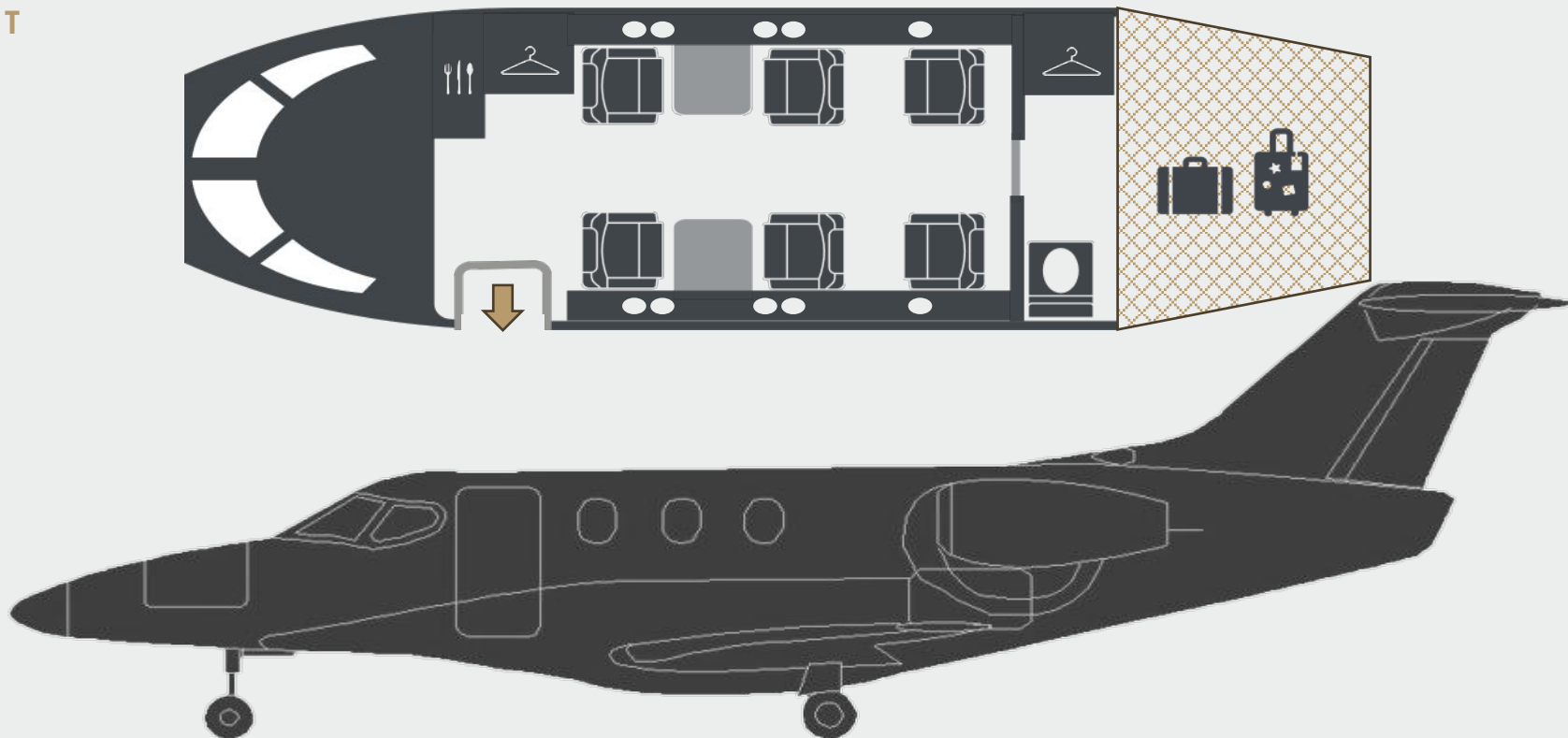



AIRCRAFT DETAILS

2003 BEECHCRAFT PREMIER I



EXTERIOR

Base Paint:

Matterhorn White

Accent Colors:

Red & Gold

Condition:

Painted in Dec 2016



*Displayed color swatches
are an approximation*





INTERIOR

2003 BEECHCRAFT PREMIER I





Forward Four (4)-Place Club Looking Aft



Drink Rail Detail



Aft Forward-Facing Seats



Aft Lav



Aft Cabin Looking Forward



Four (4)-Place Club Looking Forward



EXTERIOR

2003 BEECHCRAFT PREMIER I

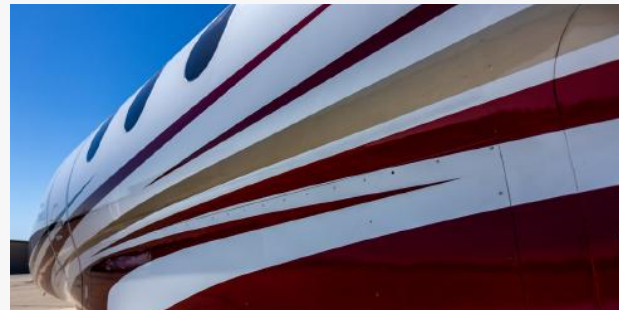



EXTERIOR

2003 BEECHCRAFT PREMIER I





EXTERIOR

2003 BEECHCRAFT PREMIER I





YOUR HEADQUARTERS



- COEUR D'ALENE, ID
- WICHITA, KS
- OKLAHOMA CITY, OK
- SCOTTSDALE, AZ
- DALLAS, TX
- MEXICO CITY, MEXICO
- KANSAS CITY, MO
- HOLMDEL, NJ
- SAVANNAH, GA
- TAMPA, FL
- BOGOTA, COLOMBIA
- BELO HORIZONTE, BRAZIL

- ZURICH, SWITZERLAND
- MILAN, ITALY
- ANKARA, TURKEY
- DUBAI, UNITED ARAB EMIRATES
- NEW DELHI, INDIA
- KUALA LUMPUR, MALAYSIA

UNITED STATES HEADQUARTERS

+1.858.397.9773
1001 NW Lou Holland Dr.
Suite 230
Kansas City, MO 64116

INTERNATIONAL HEADQUARTERS

+971.4.422.0514
Fortune Executive Tower
Unit 502
Cluster T, JLT Dubai UAE



YOUR HEADQUARTERS

FOR GLOBAL **AIRCRAFT SALES**

JETHQ was founded on the belief that the most valuable asset in aviation is trust. We strive to not simply acquire and sell aircraft for our clients but build lasting relationships.

Our team brings decades of aviation experience and real-time industry insight and analysis to each complex transaction.

Whether you are buying or selling an aircraft, be confident that JetHQ will be a dedicated partner looking out for your interests, every step of the way.

Let's start.

Founder / Managing Director